

English

Deutsch

Français

Español

Italiano

# *EZP7* *EASY Piano*

F-301 Assembly Instructions

F-301 Aufbauanleitung

Instructions d'assemblage du F-301

Instrucciones de montaje del F-301

Istruzioni di assemblaggio F-301



# F-301 Assembly Instructions

Thank you for purchasing this accessory for the Lowrey EZP7 EASY Piano.

Please read these assembly instructions thoroughly before attempting to assemble the F-301 pedal unit.



1. Do not use this F-301 for any purpose other than its intended use as a piano pedal unit.
2. At the final stage of assembly, ensure that all screws are tightened firmly.
3. Do not drag the product along the floor. Take care not to drop the product.
4. Do not exert excessive force on, or against the pedal unit.
5. If any screws are found to be loose, tighten them immediately.
6. Ensure that the adjuster bolt firmly touches the floor, supporting the pedal unit and preventing instability or damage.
7. When moving the piano, raise the Adjuster Bolt and readjust after moving.

## ■ Included parts

Before attempting to assemble the F-301 pedal unit, please ensure that all parts below are included.

A Phillips-head screwdriver (not included) will also be required in order to assemble the stand.

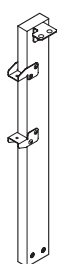

① Pedal Pillar x 2

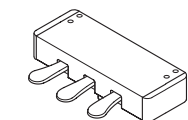
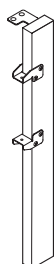

② Pedal Box x 1



③ Screw (long) x 4



④ Cross Dowel x 4



⑤ Knob x 2



⑥ Screw (short) x 4



⑦ Chord Clip x 3

## 1. Assembling the pedal box and pedal pillars

Fasten the Pedal Pillars ① to the Pedal Box ② using two long screws ③ and two Cross Dowels ④ for each pillar.

\* Ensure that all four screws are tightened firmly.

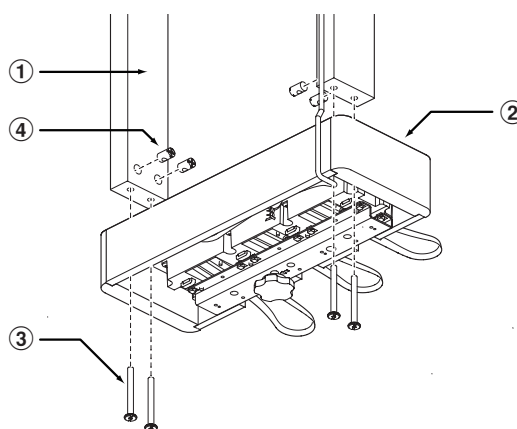

## 2. Unfastening the pedal cable

Unfasten the pedal cable from the Pedal Box ②, extending the cable approximately 10 cm longer than the Pedal Pillars ①.

Place the excess cable inside the Pedal Box and secure it using the vinyl binder.

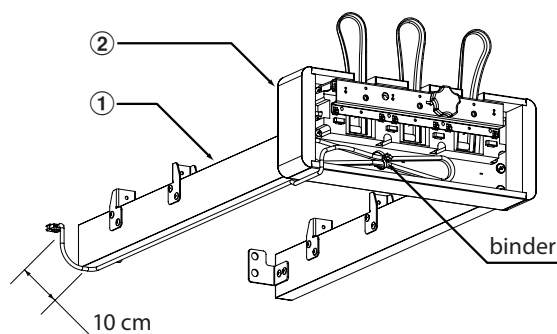

### 3. Attaching the F-301 pedal unit to the HM-4 stand

Remove the hole patches from the back board of the HM-4 stand.

Fasten the F-301 pedal unit to the HM-4 stand using four short screws ⑥ at the top and bottom of the back board.

\* Ensure that all four screws are tightened firmly.

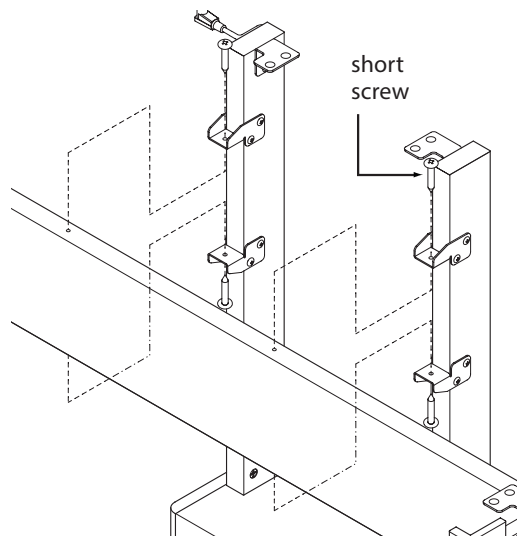
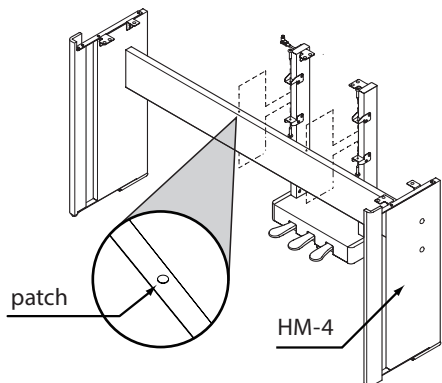

### 4. Attaching the EZP7 EASY Piano to the HM-4 stand

Fasten the underside of the EZP7 to the HM-4 stand using the four knobs included with the HM-4 stand.

\* Ensure that all four knobs are tightened firmly.

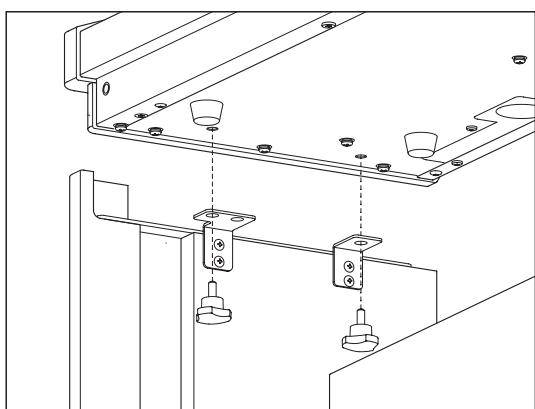

### 5. Attaching and connecting the F-301 pedal unit to the EZP7 EASY Piano

Fasten the F-301 pedal unit to the underside of the EZP7 using the two knobs ⑤.

\* Ensure that the two knobs are tightened firmly.

Plug the pedal cable connector into the PEDAL jack, then fix the cable to the pedal pillar using the Cable Clips ⑧.

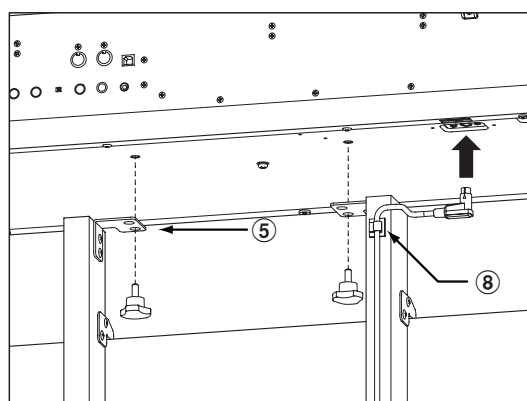

### 6. Adjusting the pedal support bolt

Turn the Adjuster Bolt at the bottom of the Pedal Box ① until the bolt fully supports the Pedal Box ①.

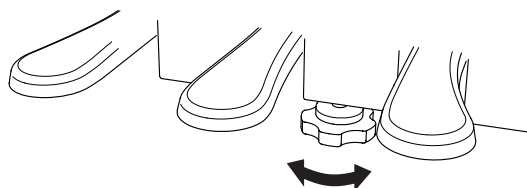

# F-301 Aufbauanleitung

Vielen Dank für den Kauf dieses Lowrey Zubehör Produktes.

Bitte lesen Sie diese Aufbauanleitung aufmerksam durch, bevor Sie mit dem Aufbau der Pedaleinheit F-301 beginnen.



1. Benutzen Sie das F-301 ausschließlich als Pedaleinheit für das EZP7.
2. Nach der Montage prüfen Sie bitte nochmal, ob alle Schrauben und Verbindungen fest sind.
3. Ziehen Sie das Produkt nicht über den Fußboden und lassen Sie es nicht fallen.
4. Stellen Sie sich nicht auf das Produkt und üben Sie keine übermäßigen Kräfte darauf aus.
5. Falls einige Schrauben locker sind, ziehen Sie diese sofort wieder fest.
6. Stellen Sie sicher, dass die Einstellschraube den Boden berührt, um Instabilität zu vermeiden.
7. Wenn Sie das Instrument bewegen, stellen Sie vorher die Einstellschraube etwas höher ein (ohne Bodenkontakt).

## ■ Beiliegende Teile

Vergewissern Sie sich vor dem Aufbau der Pedaleinheit F-301, dass alle nachfolgend aufgelisteten Teile vollständig vorhanden sind. Für den Aufbau benötigen Sie einen Kreuzschraubendreher, welcher nicht im Lieferumfang enthalten ist.

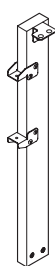

① Pedalbeine x 2

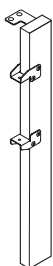

② Pedalbox x 1

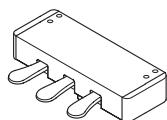

③ Schraube (lang) x 4



④ Gewindeeinsatz x 4



⑤ Einhandschraube x 2



⑥ Schraube (kurz) x 4



⑦ Kabel Clip x 3

## 1. Zusammenbau der Pedalbeine mit der Pedalbox

Verschrauben Sie die Pedalbeine ① mit der Pedalbox ② mit den 2 langen Schrauben ③ und den 2 Gewindeeinsätzen ④ für jedes Pedalbein.

\* Prüfen Sie den festen Sitz der 4 Schrauben.

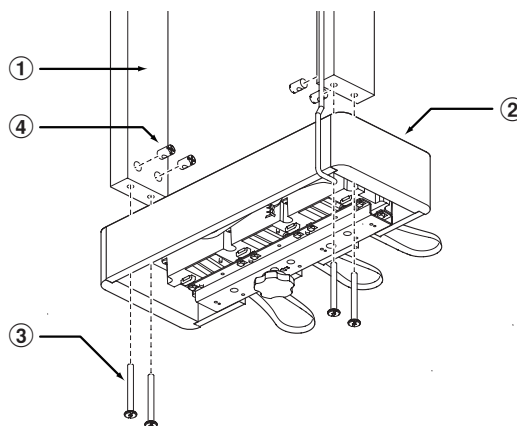

## 2. Pedalkabel lösen

Lösen Sie nun das Pedalkabel in der Pedalbox ②. Führen Sie es an das Ende des linken Pedalbeines ① und lassen Sie etwa 10 cm über stehen.

Verstauen Sie den Rest des Pedalkabels in der Pedalbox mit Hilfe des dortigen Vinylbinders.

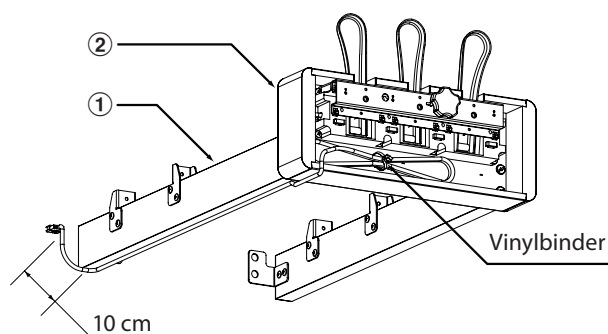

### 3. Zusammenbau der Pedaleinheit F-301 mit dem Ständer HM-4

Entfernen Sie die Aufkleber auf der Rückwand des HM-4 Ständers.

Setzen Sie die Pedaleinheit auf die Rückwand des HM-4 Ständers, sodass die Führungswinkel mit den Löchern übereinstimmen. Nun verschrauben Sie beides mit den vier kurzen Schrauben ⑥.

\* Prüfen Sie den festen Sitz der 4 Schrauben.

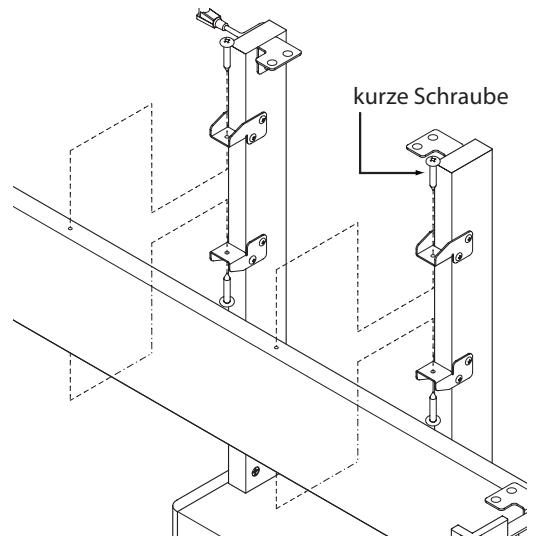
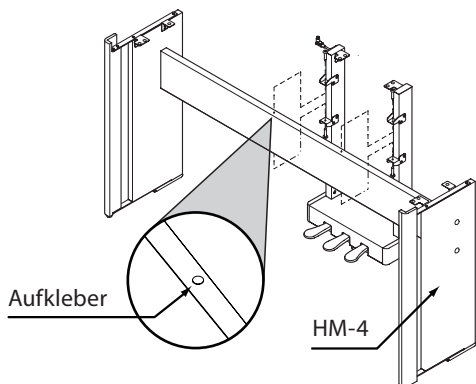

### 4. Befestigung des EZP7 auf dem Ständer

Befestigen Sie nun das ES7/ES8 mit den 4 Einhandschrauben auf dem Ständer HM-4.

\* Prüfen Sie den festen Sitz der 4 Einhandschrauben.

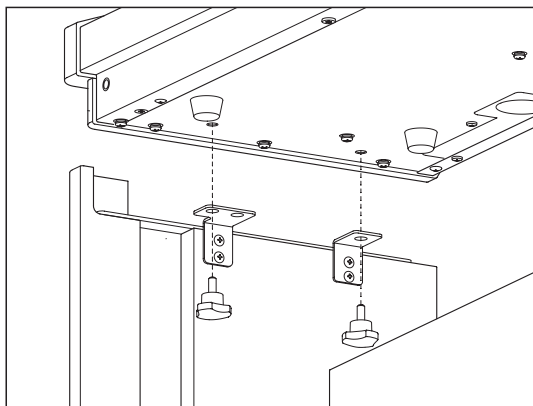

### 5. Befestigung und Anschluss der Pedaleinheit F-301 mit dem EZP7

Die Pedaleinheit F-301 wird nun mit 2 Einhandschrauben ⑤ am EZP7 befestigt.

\* Prüfen Sie den festen Sitz der 2 Einhandschrauben.

Stecken Sie den Pedalkabelstecker in die dafür vorgesehene PEDAL Buchse. Zum Schluss fixieren Sie das Pedalkabel mit Hilfe der 3 Kabel Clips ⑧ an der Rückseite des Pedalbeines.

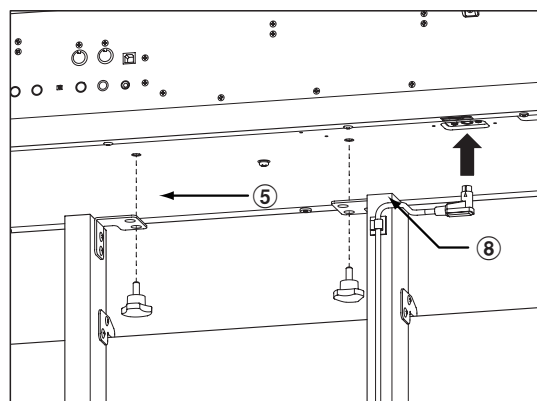

### 6. Justieren der Einstellschraube

Drehen Sie nun die Einstellschraube so weit aus der Pedalbox ① raus, dass sie den Fußboden berührt.

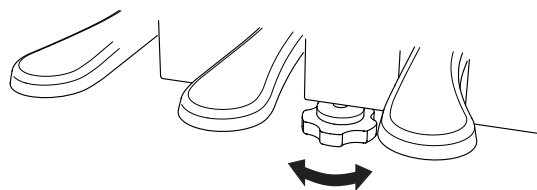

# Instructions d'assemblage du F-301

Nous vous remercions d'avoir acheté cet accessoire pour le piano Lowrey EZP7 numérique.  
Veuillez lire attentivement les instructions avant d'assembler le pédalier.



1. N'utilisez pas le pédalier F-300H à toute autre fin que celle spécifiée pour les pédaliers de piano.
2. À la fin du montage, veillez à ce que toutes les vis soient fermement serrées.
3. Ne traînez pas le produit sur le sol. Faites attention à ne pas laisser tomber le produit.
4. N'exercez pas de force démesurée sur ou contre le pédalier.
5. Si des vis se desserrent, resserrez-les immédiatement.
6. Veillez à ce que le boulon régulateur touche le sol, en soutenant le pédalier et évitant ainsi la mobilité et d'éventuels dommages.
7. Lorsque vous déplacez le piano, montez le boulon régulateur puis réajustez-le une fois le piano en place.

## ■ Pièces

Avant de commencer le montage du le F-301 pédalier, assurez-vous que toutes les pièces ci-dessous sont présentes.  
Prévoyez également un tournevis cruciforme (non inclus) pour le montage de le stand.

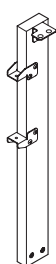

① Tige de pédale x 2

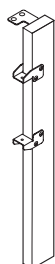

② Caisson de pédale x 1

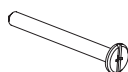
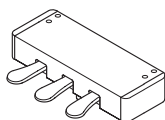

③ Vis (longue) x 4



④ Boulon de centrage en croix x 4



⑤ Boulon régulateur x 2



⑥ Vis (court) x 4



⑦ Serre-câble x 3

## 1. Assemblage du caisson de pédale et des tiges de pédale

Fixez les tiges de pédale ② au caisson de pédale ① à l'aide ③ de deux boulons de centrage en croix ④ pour chaque tige.

\* Veillez à ce que toutes les vis soient fermement serrées.

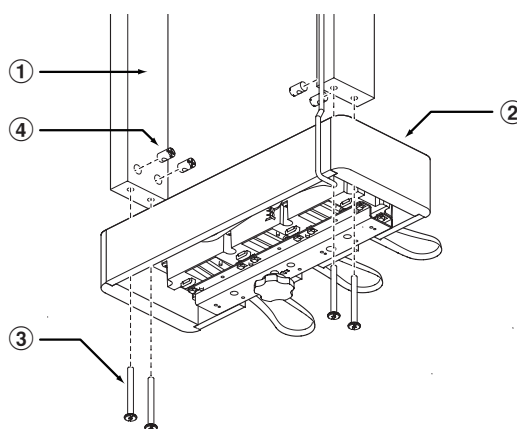

## 2. Dégagement du câble de pédale

Dérivez le câble de pédale du caisson de pédale ②, en donnant au câble environ 10 cm de plus que la tige de pédale ①.

Remettez l'excédant de câble dans le caisson de pédale et attachez-le avec le lien en vinyle.

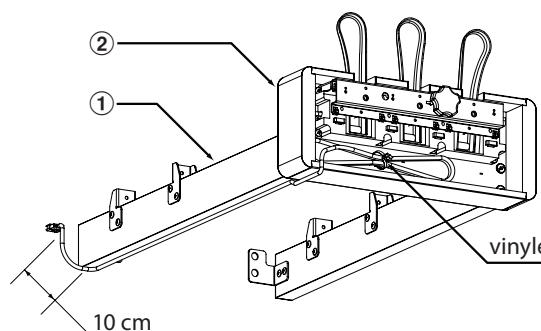

### 3. Fixation du pédalier F-301 au stand HM-4

Retirez les protections d'orifice du pied HM-4.

Fixez le pédalier F-301 au pied HM-4 à l'aide des quatre vis courtes ⑥ en haut et en bas du panneau arrière.

\* Veillez à ce que toutes les vis soient fermement serrées.

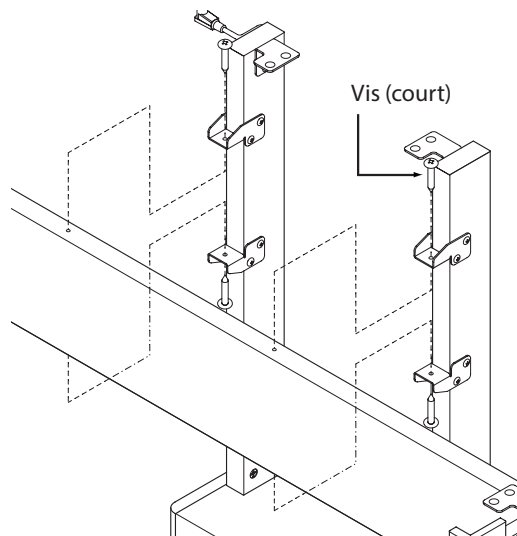
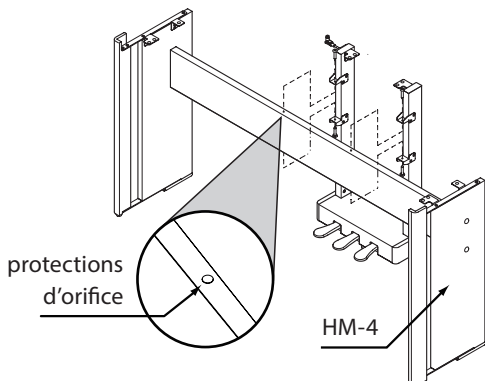

### 4. Fixation du piano numérique EZP7 au stand HM-4

Fixez la face inférieure du piano numérique EZP7 au stand HM-4 à l'aide des quatre molettes de serrage livrées avec ce dernier.

\* Assurez-vous que les quatre molettes sont bien serrées.

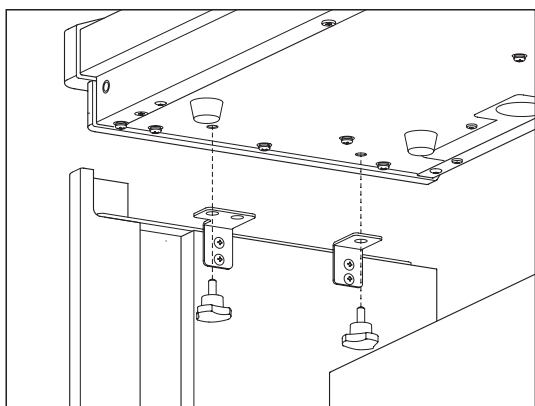

### 5. Fixation et connexion du pédalier F-301 au piano numérique EZP7

Fixez le pédalier F-301 à la face inférieure du piano numérique EZP7 à l'aide des deux molettes de serrage ⑤.

\* Assurez-vous que les deux molettes sont bien serrées.

Branchez le connecteur du câble de pédale dans la mini-prise PEDAL puis fixez le câble à la tige de pédale à l'aide des serre-câbles ⑧.

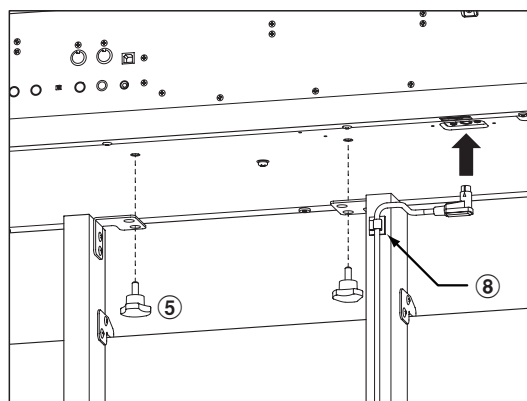

### 6. Réglage du boulon régulateur de pédalier

Tournez le boulon régulateur (à molette) au bas du caisson de pédale ① jusqu'à ce qu'il soutienne parfaitement ce dernier ②.

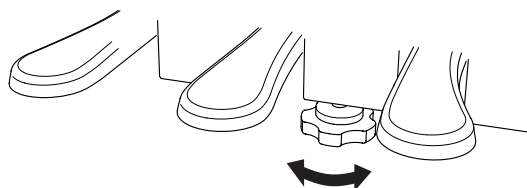

# Instrucciones de montaje del F-301

Gracias por adquirir este accesorio para el piano digital Lowrey EZP7.

Lea atentamente estas instrucciones de montaje antes de montar la unidad de pedal F-301.



1. No utilice el F-301 para cualquier fin distinto a su uso previsto como pedal de piano.
2. En la etapa final de montaje, asegúrese de que todos los tornillos estén bien apretados.
3. No arrastre el producto por el suelo. Tenga cuidado de no dejar caer el producto.
4. No ejerza presión excesiva sobre, o contra, el pedal.
5. Si algún tornillo se afloja, apriételo inmediatamente
6. Asegúrese de que el tornillo de ajuste quede bien apoyado contra el suelo, dando apoyo a la unidad de pedal y evitando inestabilidad o desperfectos.
7. Al mover el piano, elevar el tornillo de ajuste y reajustar después de haber realizado el cambio de sitio.

## ■ Piezas incluidas

Antes de montar la unidad de pedal F-301, asegúrese de que todas las piezas mostradas más abajo vienen incluidas. Un destornillador Phillips (no incluido) también será necesario para montar el soporte.

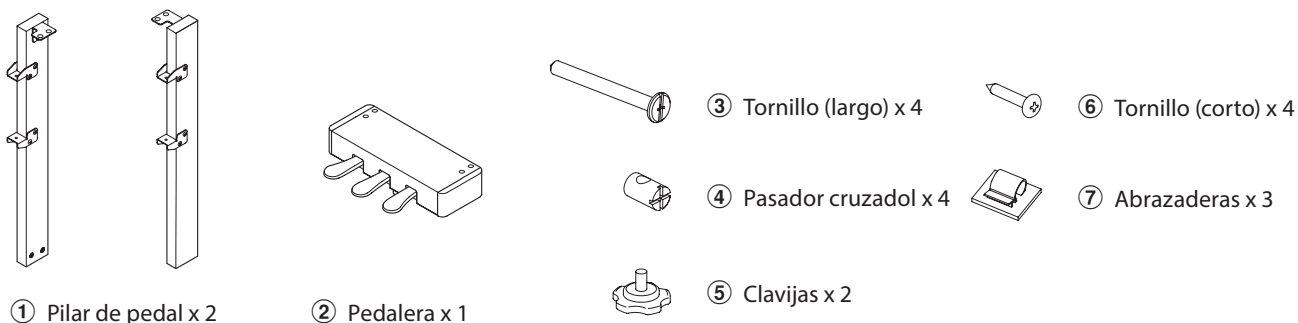

## 1. Montaje de la caja de pedales y los pilares del pedal

Fije los pilares del pedal ① a la pedalera ② con dos tornillos largos ③, y dos clavijas en cruz ④ para cada pilar.

\* Asegúrese de que los cuatro tornillos están bien apretados.

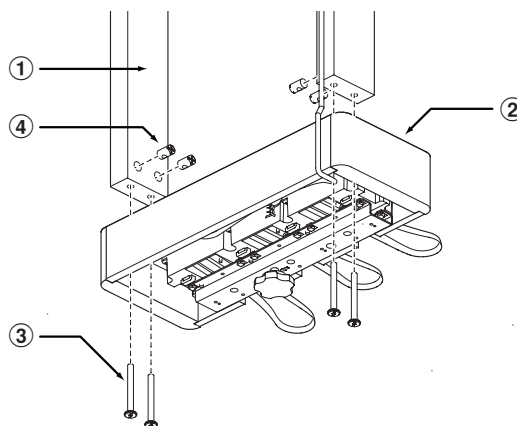

## 2. Aflojar el cable del pedal

Afloje el cable del pedal de la pedalera ②, de tal forma que sea aproximadamente 10 cm más largo que los pilares del pedal ①.

Coloque el exceso de cable dentro de la caja del pedal y fíjelo con una cinta de vinilo o brida.

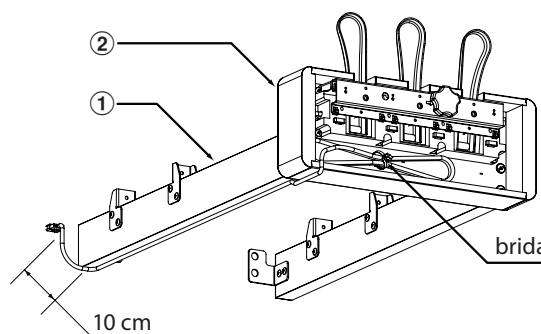



### 3. Acoplar la unidad de pedal F-301 al soporte HM-4

Retire los parches de los agujeros de la placa trasera del soporte HM-4.

Fije la unidad de pedal F-301 al soporte HM-4 utilizando cuatro tornillos cortos ⑥ en la parte superior e inferior de la placa trasera.

\* Asegúrese de que los cuatro tornillos están bien apretados.

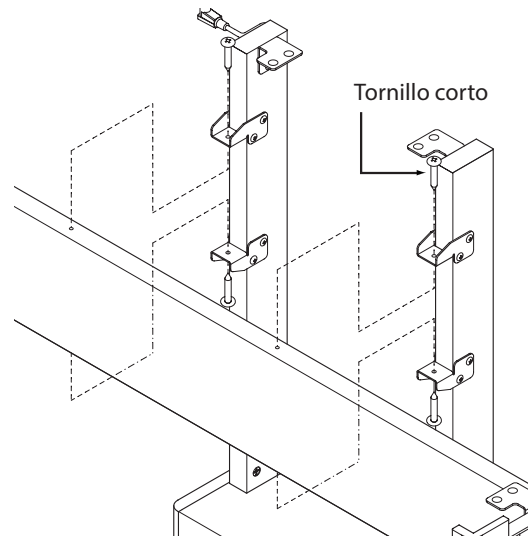
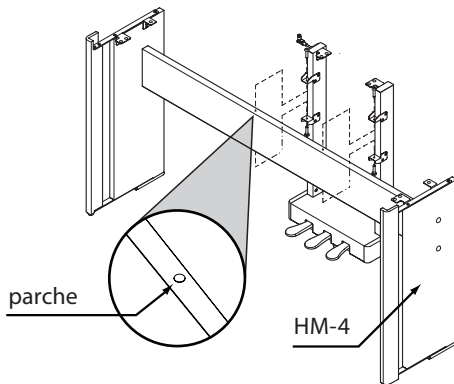

### 4. Acoplar el piano digital EZP7 al soporte HM-4

Fije la parte inferior del piano digital EZP7 al soporte HM-4 utilizando las cuatro clavijas incluidas con el soporte HM-4.

\* Asegúrese de que las cuatro clavijas están bien apretadas.

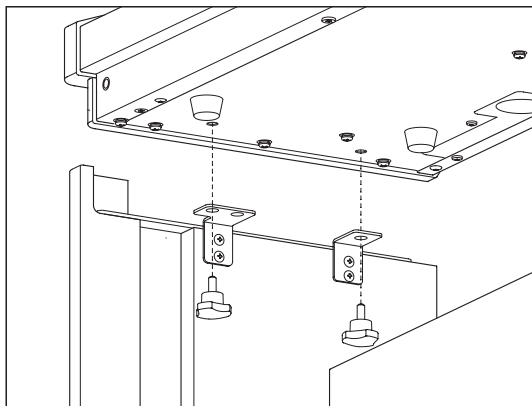

### 5. Acoplar y conectar la unidad de pedal F-301 al piano digital EZP7

Fije la unidad de pedal F-301 a la parte inferior del piano digital EZP7 usando dos clavijas ⑤.

\* Asegúrese de que las dos clavijas están bien apretadas.

Conecte el conector del cable en el jack del PEDAL, seguidamente, fije el cable al pilar del pedal utilizando las abrazaderas ⑧.

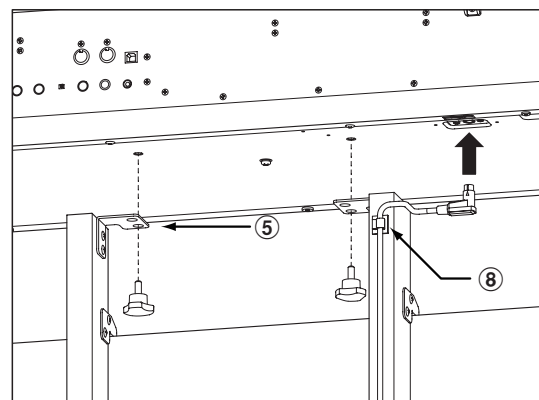

### 6. Ajustar el tornillo de soporte del pedal

Gire el tornillo de ajuste en la parte inferior de la pedalera ① hasta que éste soporte perfectamente la pedalera ①.

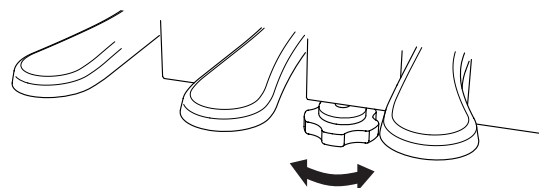

# Istruzioni per il montaggio del pedale triplo F-301

Vi ringraziamo per aver acquistato questo accessorio destinato al pianoforte digitale EZP7.

Vi preghiamo leggere attentamente le istruzioni che seguono prima di accingervi a montare il pedale triplo F-301.



1. Non utilizzate il pedale triplo F-301 per usi diversi da quello di pedali per pianoforte digitale.
2. Al termine dello assemblaggio assicurarsi che tutte le viti siano ben fissate.
3. Non trascinare il prodotto sul pavimento o non lasciarlo cadere.
4. Non esercitare forza eccessiva sui o verso i pedali.
5. Se qualche vite fosse allentata, fissarla immediatamente.
6. Assicurarsi che la manopola regolatrice tocchi con fermezza il pavimento in modo da supportare la pedaliera ed evitare instabilità o danni.
7. In caso di spostamento dello strumento rialzare la manopola e regolarla nuovamente dopo lo spostamento.

## Parti

Prima di procedere all'assemblaggio del pedale triplo F-301, assicurarsi che tutte le parti sotto illustrate siano presenti. E' inoltre necessario un avvitatore Phillips (non in dotazione).

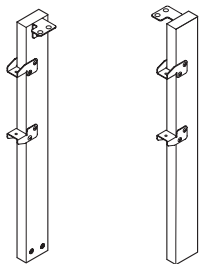

① Pilastrini per i pedali x 2

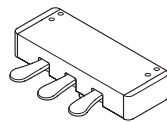

② Pedaliera x 1

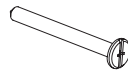

③ Viti (lunghe) x 4



④ Perno a croce x 4



⑤ Manopole x 2



⑥ Viti (corte) x 4



⑦ Ferma cavo x 3

## 1. Assemblare la pedaliera e i relativi pilastrini

Unire i pilastrini ① alla pedaliera ② con due viti lunghe ③ e due perni a croce ④ per ogni pilastrino.

\* Assicurarsi che tutte le quattro viti siano fissate saldamente.

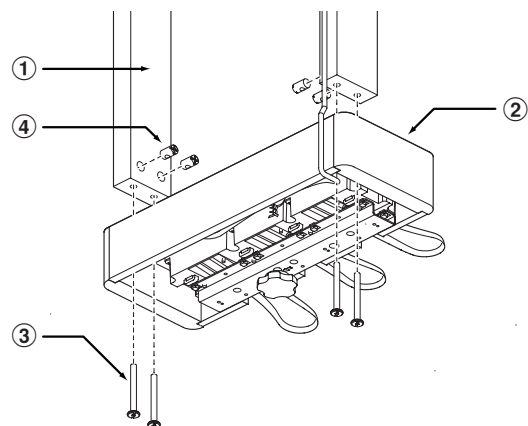

## 2. Svolgere il cavo dei pedali

Svolgere il cavo dalla pedaliera ② estendendolo per circa 10 cm. oltre i pilastrini ①.

Posizionare il cavo in eccesso all'interno della pedaliera e fissarli con il legante in vinile.

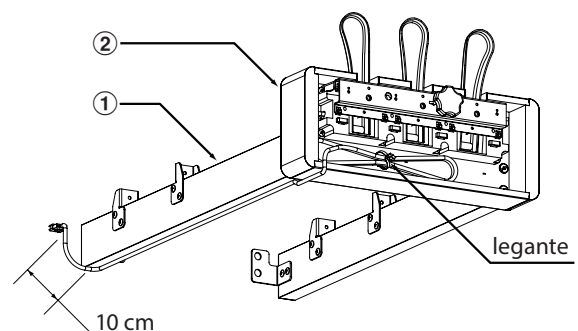

### 3. Unire il pedale triplo F-301 al supporto HM-4

Rimuovere i copri fori dal pannello posteriore del supporto HM-4.

Unire il pedale F-301 al supporto HM-4 con quattro viti corte ⑥ sopra e sotto il pannello posteriore

\* Assicurarsi che tutte e quattro le viti siano fissate saldamente.

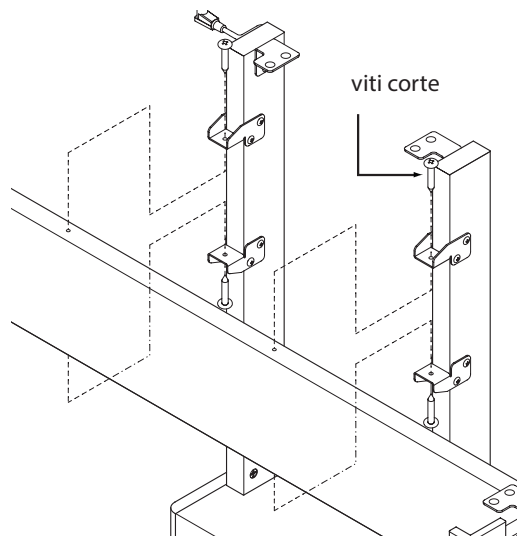
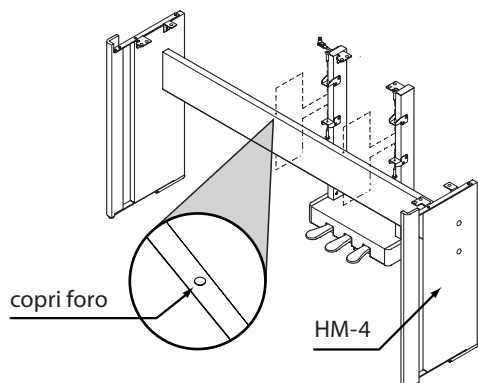

### 4. Unire il pianoforte digitale EZP7 al supporto HM-4

Fissare la parte inferiore del pianoforte digitale EZP7 al supporto HM-4 con le 4 manopole in dotazione allo stesso.

\*Assicurarsi che tutte e quattro le manopole siano fissate saldamente.

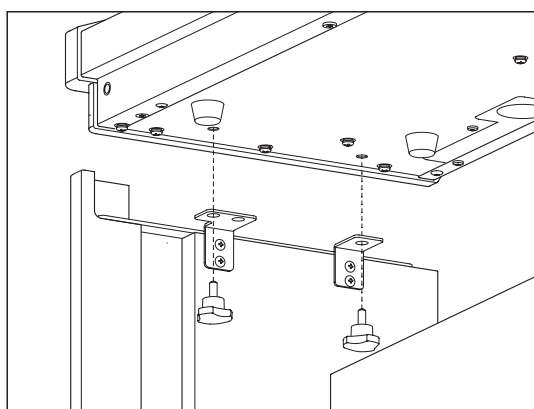

### 5. Unire e collegare il pedale triplo F-301 al pianoforte digitale EZP7

Fissare il pedale F-301 alla parte sottostante del pianoforte EZP7 con le due manopole ⑤.

\* Assicurarsi che tutte e due le manopole siano fissate saldamente.

Inserire il cavo di connessione dei pedali nella presa PEDAL, quindi fissare il cavo al pilastro utilizzando le relative graffette ⑧.

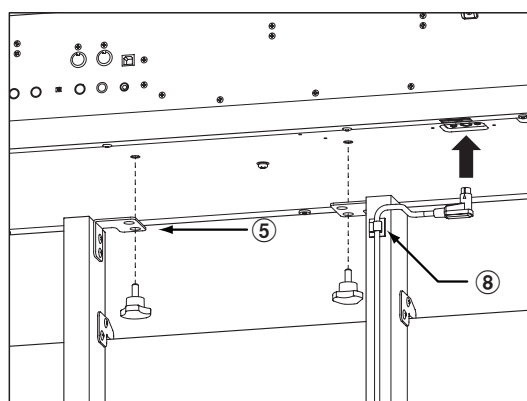

### 6. Regolare la manopola di supporto dei pedali

Ruotare la manopola regolatrice sotto la pedaliera ① sino a quando la manopola non sostiene perfettamente la pedaliera ①.

